

1 1/16" BORE STAINLESS STEEL CYLINDER



SFR-17-□-□

Double Acting, Spring Bias



Mount: Stud **Standard Stroke Lengths:** 1/2", 1", 1-1/2", 2", 3", 4"
Type: Rotating Rod **Spring Compressed:** 7 lbs. **Spring At Rest:** 2 lbs.
Options: MB, B, H, W, V, P6, P7, P8, S, N For magnetic bumpers add .312
 For S option add .250

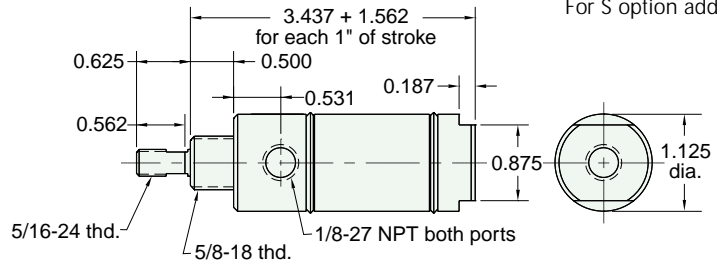

Nut included, but not shown on drawing

UBR-17-□-□

Double Acting, Rear Spring Bias



Mount: Universal **Standard Stroke Lengths:** 1/2", 1", 1-1/2", 2", 3", 4"
Type: Rotating Rod **Spring Compressed:** 7 lbs. **Spring At Rest:** 2 lbs.
Options: MB, B, H, W, V, P2, P3, P4, P5, P6, P7, P8, N For magnetic bumpers add .312

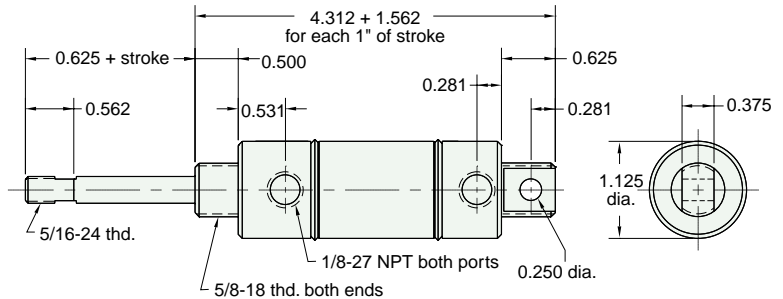

Furnished without nut(s). See Chart on Page 34.

UFR-17-□-□

Double Acting Front Spring Bias



Mount: Universal **Standard Stroke Lengths:** 1/2", 1", 1-1/2", 2", 3", 4"
Type: Rotating Rod **Spring Compressed:** 7 lbs. **Spring At Rest:** 2 lbs.
Options: MB, B, H, W, V, P2, P3, P4, P5, P6, P7, P8, N For magnetic bumpers add .312

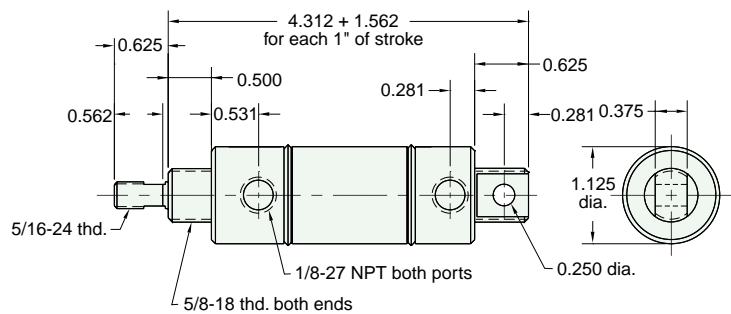

Furnished without nut(s). See Chart on Page 34.